

**END VIEW**

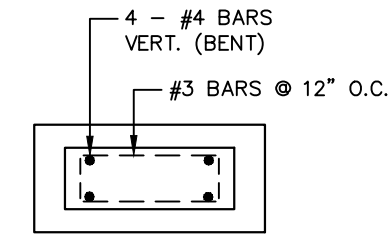

**SECTION "A-A"**

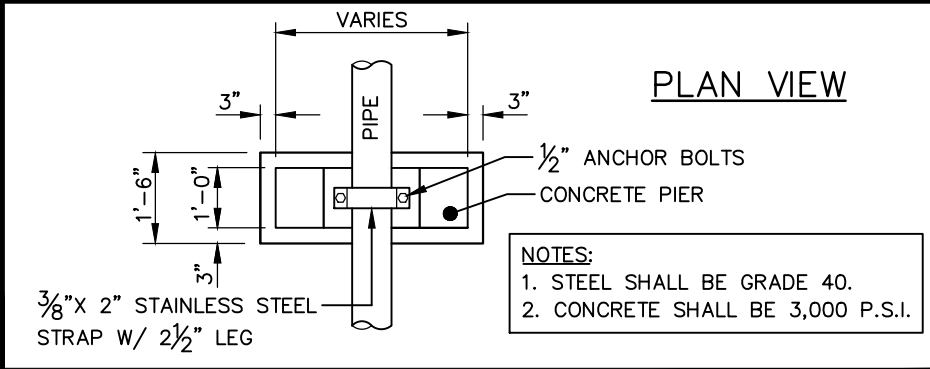

**PLAN VIEW**

- NOTES:**
1. STEEL SHALL BE GRADE 40.
  2. CONCRETE SHALL BE 3,000 P.S.I.

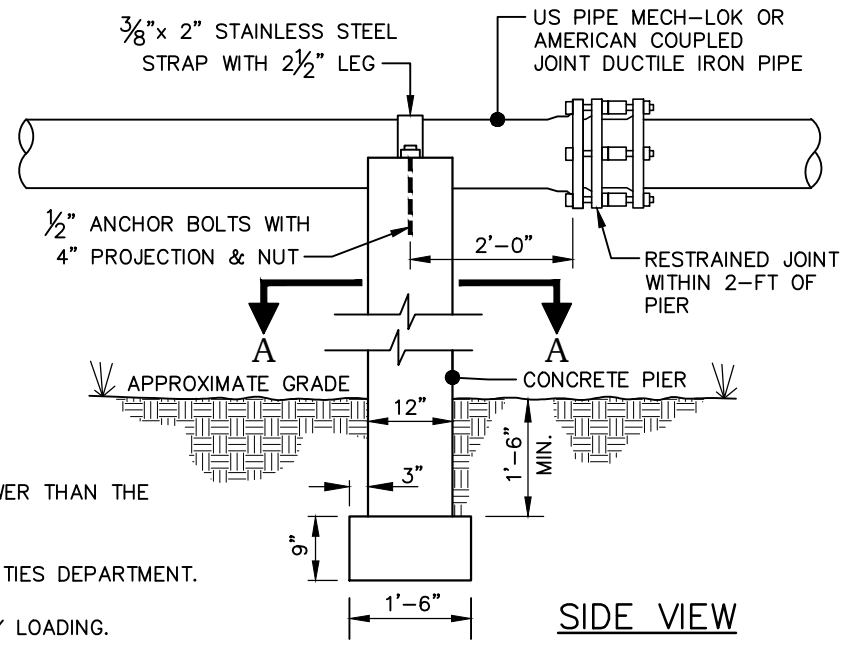

**SIDE VIEW**

- NOTES:**
1. PIERS OVER 3 FEET IN HEIGHT TO BE REINFORCED.
  2. BOTTOM OF PIPE MUST BE A MINIMUM OF 24 INCHES ABOVE NORMAL WATER LEVEL BUT NO LOWER THAN THE 25-YEAR FLOOD ELEVATION.
  3. CAST-IN-PLACE CONCRETE SHALL BE FIELD TESTED.
  4. AT A MINIMUM, ONE PIER MUST BE INSTALLED EVERY 20 FEET OR AS DIRECTED BY CARY'S UTILITIES DEPARTMENT.
  5. FOOTING DESIGN SHALL BE CONFIRMED BY LICENSED N.C. PROFESSIONAL ENGINEER.
  6. SUBSURFACE CONDITIONS SHALL BE CONFIRMED BY LICENSED N.C. GEOTECH ENGINEER TO VERIFY LOADING.
  7. PRECAST PIERS REVIEWED ON CASE BY CASE BASIS.
  8. PIPE SHALL BE LINED WITH CARY APPROVED LINING FROM MANHOLE TO MANHOLE.
  9. PIER FOUNDATION SUPPORT TYPE SHALL BE DETERMINED BY LICENSED NC PE BASED ON SUBGRADE CONDITIONS AND AT EACH PIER LOCATION INUNDATED IN THE 100-YEAR DESIGN STORM EVENT INCLUDE FOUNDATION ANCHOR DESIGN.
  10. EACH PIER EXPOSED TO THE 100-YEAR DESIGN STORM EVENT SHALL BE PROTECTED BY APPROPRIATELY SIZED RIP RAP THAT EXTENDS A MINIMUM OF 6- FEET BEYOND THE PIER.
  11. STREAM BANK SLOPES BENEATH THE AERIAL CROSSING SHALL BE PROTECTED BY APPROPRIATELY SIZED RIP RAP AND EXTEND A MINIMUM OF 6- FEET BEYOND THE CENTERLINE OF THE PIPE UPSTREAM AND DOWNSTREAM. RIP RAP SHALL NOT BE ALLOWED IN THE STREAM BED.



EFFECTIVE: 07/01/21

**ALTERNATE AERIAL CROSSING  
(8-FT MAXIMUM PIER HEIGHT)**

DETAIL No.  
7000.28