

BASE UNIT INSTALLMENT

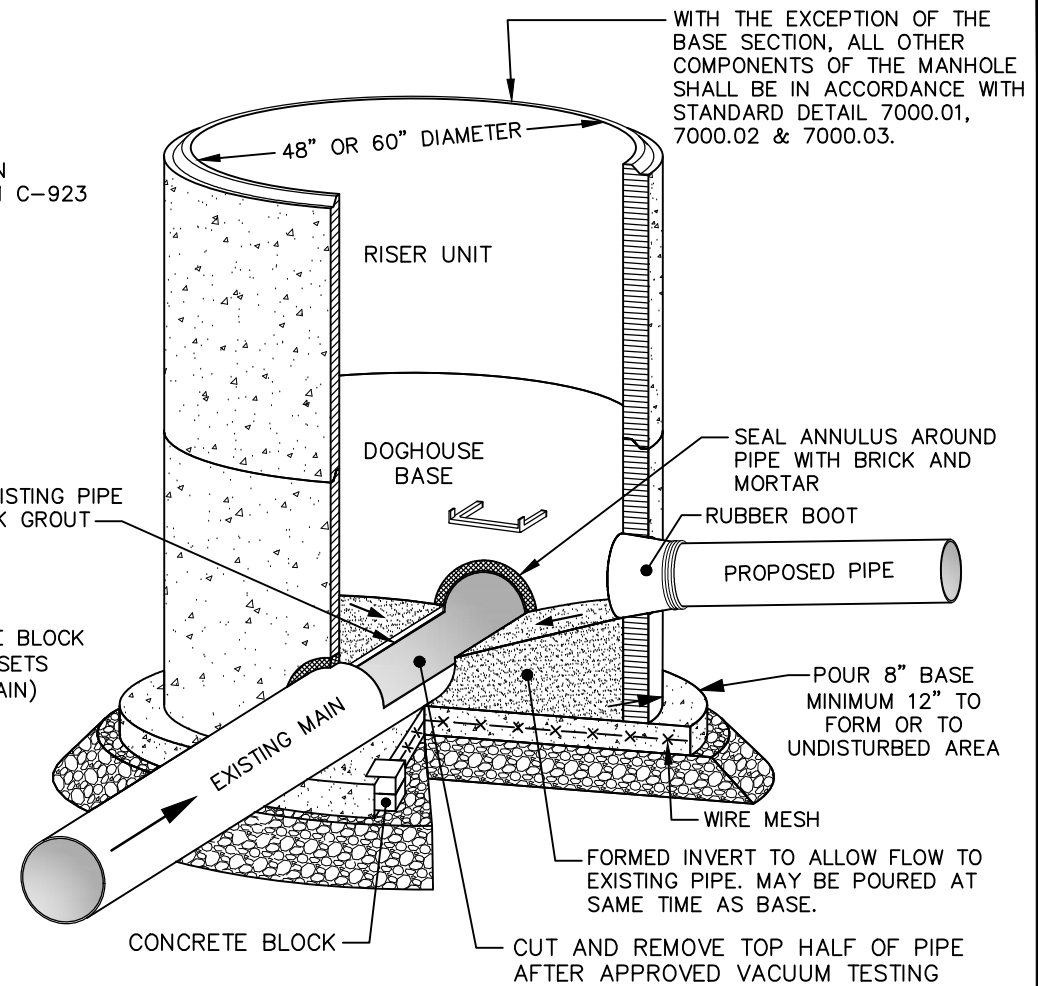

INVERT INSTALLMENT

WITH THE EXCEPTION OF THE BASE SECTION, ALL OTHER COMPONENTS OF THE MANHOLE SHALL BE IN ACCORDANCE WITH STANDARD DETAIL 7000.01, 7000.02 & 7000.03.

NOTES:

1. DOGHOUSE OPENINGS IN PRECAST UNITS SHALL HAVE A RADIUS OF 4 TO 8 INCHES LARGER THAN THE EXISTING PIPE DIAMETER.
2. CAST-IN-PLACE CONCRETE SHALL BE 4000 PSI, PER ASTM C-94.
3. ALL PRECAST MANHOLE COMPONENTS SHALL MEET ASTM C-478.
4. BENCH SHALL SLOPE UPWARD FROM THE SPRINGLINE TO THE PROJECTED LEVEL OF THE PIPE CROWN OR 8 INCHES ABOVE THE SPRINGLINE, WHICHEVER IS LESS.



EFFECTIVE: 07/01/22

STANDARD PRECAST CONCRETE DOGHOUSE MANHOLE

DETAIL No.

7000.06