

GALVANIZED 24 GAUGE MINIMUM WIRE MESH HARDWARE CLOTH, 1/4" OPENINGS (ON ALL FOUR SIDES)

STANDARD METAL POSTS 2'-0" IN GROUND

#57 WASHED STONE PLACED TO A HEIGHT OF 12"-18" MINIMUM ABOVE TOP OF BOX (AROUND ALL FOUR SIDES)

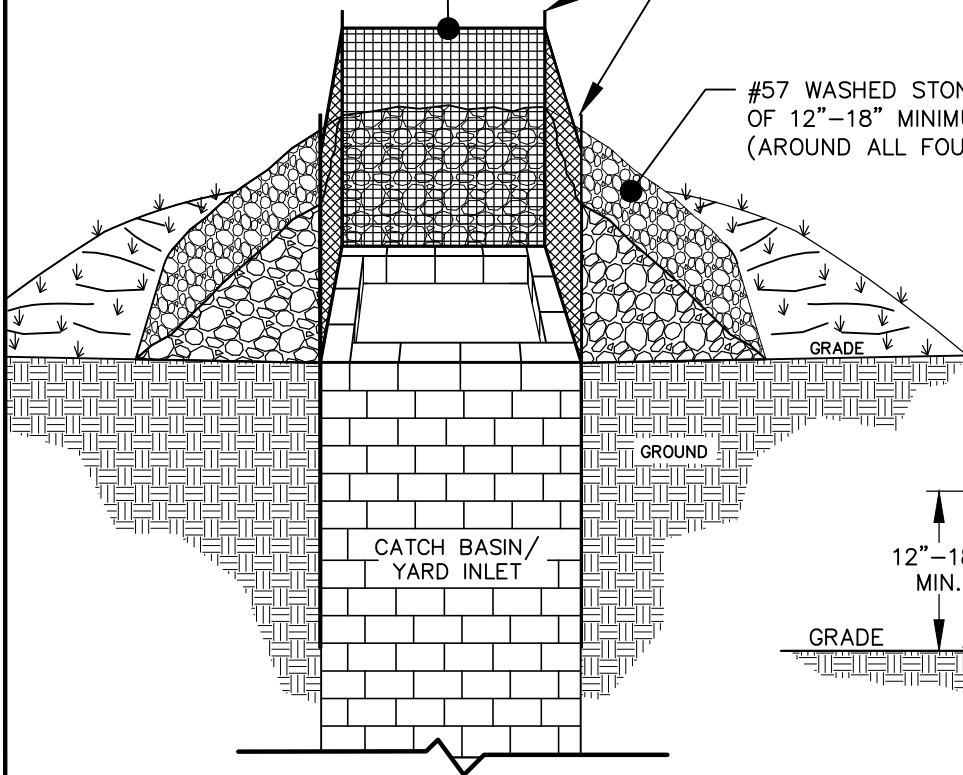

FRONT CUT-AWAY VIEW

MAINTENANCE:

1. INSPECT WEEKLY AND AFTER EACH RAINFALL EVENT.
2. CLEAR THE MESH WIRE OF ANY DEBRIS OR OTHER OBJECTS TO PROVIDE ADEQUATE FLOW FOR SUBSEQUENT RAINS.
3. TAKE CARE NOT TO DAMAGE OR UNDERCUT THE WIRE MESH DURING SEDIMENT REMOVAL.
4. REPLACE STONE AS NEEDED.

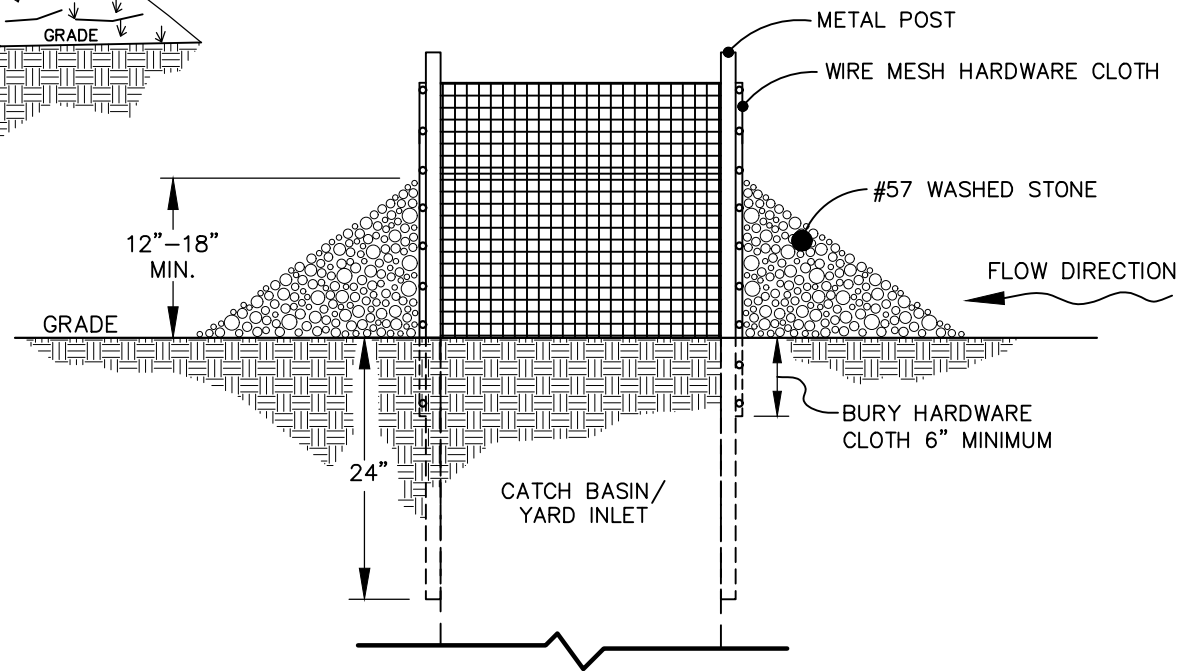

FRONT SECTION VIEW



EFFECTIVE: 07/01/23

STANDARD CATCH BASIN/YARD INLET PROTECTION

DETAIL No.

4000.14