

ENGINEER SHALL DESIGN MANHOLE TO ALLOW FOR ADEQUATE ROOM TO INSTALL THE ARV AND APPURTENANCES SHOWN. VERIFY ADEQUATE CLEARANCES FOR ARVS LISTED ON CARY'S APPROVED PRODUCTS LIST.

4'-0" MINIMUM

16" MIN.
6" MIN.
12" MINIMUM

5'-0" OR 6'-0" DIAMETER
(SEE REQUIRED MANHOLE DIAMETER)

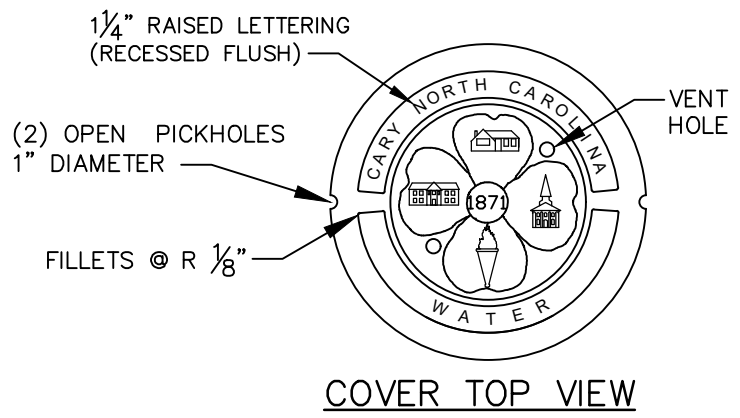

COVER TOP VIEW

RING & COVER SPECIFICATIONS:

1. CLASS 35 GREY IRON.
2. COMPLIES WITH ASTM A48 CL35B.
3. ALL LETTERING SHALL BE CLEAN, CRISP, AND CLEARLY LEGIBLE.
4. DOMESTICALLY MADE & MANUFACTURED IN THE USA.

MINIMUM WEIGHTS	
RING	180
COVER	120
TOTAL	300

REQUIRED MANHOLE DIAMETER:
 MAIN ≤ 20" = 5'-0" ∅
 MAIN > 20" = 6'-0" ∅

FOUR 3/8" x 4 1/2" ANCHOR BOLTS

1/2" MINIMUM

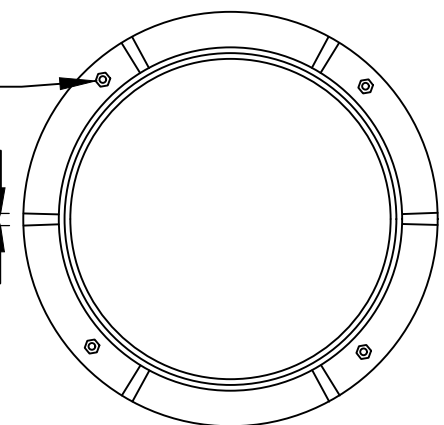

RING TOP VIEW

NOTES:

1. ISOLATION GATE VALVE TO BE SAME SIZE AS AIR VALVE.
2. ARV MANHOLE SHALL BE PROVIDED WITHOUT STEPS.
3. RESILIENT CONNECTORS OR BOOTS MEETING ASTM C923 SHALL BE USED AT THE MANHOLE AND PIPE INTERFACE.
4. MANHOLES DEEPER THAN 12 FEET REQUIRE AN EXTENDED BASE.

**STANDARD 3" AND GREATER COMBINATION AIR VALVE
(FOR POTABLE WATER SYSTEMS)**

DETAIL No.

6000.24



EFFECTIVE: 07/01/24